



FULL SERVICE-VDSL COMMITTEE

FS-VDSL Specification

Part 5

FINAL
June 5, 2002

Normative Specification

OAM & P Specification

FS-VDSL Working Group: OAM & P

Chair : Terry Shannon, Bell Canada

Editor : Steve Highfield, BT

FS-VDSL SPECIFICATIONS

PART 5:

Part 1 : Operator Requirements

Part 2 : System Architecture Specification

Part 3 : Customer Premises Equipment Specification

Part 4 : Physical Layer Specification for Interoperable VDSL Systems

Part 5 : OAM & P Specification

FS-VDSL Specifications Part 5

OAM & P SPECIFICATION

Summary

This specification addresses VDSL service provisioning and service assurance requirements for video, data and voice services on an end to end VDSL platform. It addresses four key areas for VDSL technology – 1) ONU and OLT, 2) Access Network, 3) VTP and 4) Element management system (EMS).

Source

This document was prepared by FS-VDSL OAM & P Working Group

CONTENTS

1. Scope	5
2. Abbreviations	6
3. Definitions	9
4. References	11
5. Functional Diagram	12
6. Network Provision	14
6.1. Introduction	14
6.2. Stage 1 - Build the network	15
6.2.1 Auto Discovery and Auto Configure	15
6.3. Stage 2 - Provide Service	15
6.3.1 Installation of the VTP	15
6.3.2 Management of the VTP/D	15
6.3.3 Setting up flows	16
6.4. Stage 3 – Access control	17
7. Network Data Management	19
7.1. Usage data	19
7.1.1 Ensuring accuracy of usage information	19
7.2. Topology (relationship between equipment and services)	19
7.3. Utilisation / capacity management	20
7.4. Equipment information	20
8. Service Quality Management	21
9. FS-VDSL Network Maintenance and Restoration	22
9.1. General requirements	22
9.2. Element Management System	23
9.3. Modem information required	23
9.4. VTP information required	23
9.5. Line	23
9.6. VDSL Interface	24
9.7. Event Handling	24
9.8. ONU CPU	24
9.9. Optical Interface	24
9.10. ONU	25
9.11. ATM	25
10. OSS	26
10.1. Software upgrades	26
10.1.1 VTP/D Software	26
10.1.2 VDSL Platform Software	27

10.2. Element Management System	27
10.2.1 EMS Administration	28
10.2.2 EMS Equipment Provisioning	29
10.2.3 EMS Service Provisioning	29
10.3. OSS: Additional OAM&P Requirements	30
10.3.1 OSS Operating Systems Supported	30
10.3.2 OSS Hardware Platforms Supported	30
10.3.3 OSS User Interaction Supported	30
10.3.4 OSS Workstation Requirements	30
10.3.5 Service Management	30
10.3.6 Fault Management	31
10.3.7 Configuration Management	31
10.3.8 Content Management	32
10.3.9 Billing	32
11. Interfaces To the FS-VDSL Platform	33
11.1. General Interface Requirements	33
11.2. To support Service Planning and Development	33
11.3. To support Rating and Discounting	33
11.4. To support Network Provisioning	33
11.4.1 To platform	33
11.4.2 From platform	34
11.5. To support Network Provisioning	34
11.6. To support Network Provisioning	34
11.7. Output from Network Provisioning	34
11.8. To support Invoicing and Collection	34
11.8.1 To the Platform	35
11.8.2 From the platform	35
11.9. To support Network Inventory Management and Network Planning and Development	35
11.9.1 To the Platform	35
11.9.2 From the Platform	35
11.10. QoS parameters to Customer QoS Management	36
11.10.1 To the platform	36
11.10.2 From the platform	36
11.11. To support FS-VDSL Network Maintenance and Restoration	36
11.11.1 To the Platform	36
11.11.2 From the Platform	36
11.12. To support Service Problem Resolution and FS-VDSL Network Maintenance and Restoration	37
11.12.1 To the platform	37
11.12.2 From the platform	37
11.13. To support Access Control Functions	37
11.13.1 To the platform	37
11.13.2 From the platform	37
12. VTP/D - additional OAM&P requirements	38
12.1. VTP/D Management Functions	38
12.2. VTP/D Management Interfaces	39
12.3. VTP/D Management Protocol Support	40

12.4. VTP/D Diagnostics	40
12.5. VTP/D Fault Management	40
12.6. VTP/D Configuration Management	41
12.7. VTP/D Performance Management	41
12.8. VTP/D Security Management	41
13. Training	42
13.1. VTP/D Installation Tasks	42
13.2. OSS Administration Tasks	44
Figure 1 Functional Diagram	12
Figure 2 Network Provision Functionality	13
Figure 3 Access Control Channels	17

Introduction

The OAM&P of a telecommunications network can be broken down into a number of distinct functions. One example of this is the TOM model from TMN. The approach taken to the FS-VDSL OAM has been to consider in turn each of the main functions defined by TOM and to decide if they should form part of the FS-VDSL specification.

FS-VDSL SPECIFICATIONS Part 5

OAM & P SPECIFICATION

(Oslo, 2002)

1. SCOPE

This specification is the result of the FS-VDSL OAM&P Working Group's objective to produce a document that will address VDSL service provisioning and service assurance requirements for video, data and voice services on an end to end VDSL platform. This document addresses four key areas of VDSL technology – 1) ONU and OLT, 2) Access Network, 3) VTP and 4) EMS Element Management Systems. The TOM model was used as a reference point in discussions where various categories were defined and addressed. Intent is to define VDSL operational requirements and specifications that enable the provisioning of bundled services in a reliable way with minimal user intervention and at a cost compatible with mass market deployment. FS-VDSL OAM&P specifications shall be based on published industry wide standards where possible.

2. ABBREVIATIONS

This specification uses the following abbreviations:

Acronym	Expansions
AAL2	ATM Adaptation Layer 2
AC	Alternating Current
AEG	Architectural Experts Group (FS-VDSL)
ATM	Asynchronous Transfer Mode
BLES	Broadband Loop Emulated Service
CBR	Constant Bit Rate
CMISE	Common Management Information Service Element [ISO]
CO	Central Office
CORBA	Common Object Request Brokerage Architecture
CPU	Central Processing Unit
CRC	Cyclic Redundancy Check
DRP	Disaster Recovery Plan
DSL	Digital Subscriber Line
DSLAM	Digital Subscriber Line Access Multiplexer
DSM-CC	Digital Storage Media - Command and Control
EMS	Element Management System]
F4	Flow 4 [ATM]
F5	Flow 5 [ATM]
FPD	Functional processing and Decoding block
FRU	Field Replaceable Unit
FS-VDSL	Full Service Access Network - Very high speed Digital Subscriber Line
GUI	Graphical User Interface
HTML	HyperText Mark-up Language [W3C]
HTTP	HyperText Transfer Protocol
I.610	B-ISDN operation and maintenance principles and functions [ITU-T]
ISDN	Integrated Services Digital Network
IGMP	Interior Group Management Protocol [IETF]

ILMI	Interim Local Management Interface
IP	Internet Protocol [IETF]
LAN	Local Area Network
LED	Light-Emitting Diode
MAC	Media Access Control
MIB	Management Information Base [IETF]
MPEG	Moving Picture Experts Group
NML	Network Management Layer
NO	Network Operator
OAM	Operations Administration and Maintenance
OAM&P	Operations Administration and Maintenance & Provision
OF	Optical Fibre
OLT	Optical Line Termination
ONU	Optical Network Unit
OSS	Operational Support System
PC	Personal/Portable Computer
PCI	Protocol Control Information
PCR	Peak Cell Rate
POTS	Plain Old Telephony Service
PPPoA	Point-to-Point Protocol over Asynchronous Transfer Mode
PPPoE	Point-to-Point Protocol over Ethernet [IETF]
PPV	Pay Per View
PSTN	Public Switched Telephone Network
QoS	Quality of Service
RFC	Request for Comment [IETF]
RPS	Remote Power Supply
SA	System Architecture Group (FS VDSL)
SNAP	Sub Network Access Protocol
SNMP	Simple Network Management Protocol [IETF]
SNR	Signal/Noise Ratio
SP	Service Provider

TFTP	Trivial File Transfer Protocol [IETF]
TOM	Telecom Operations Map
TV	Television
UBR	Unspecified Bit Rate
UDP	User Datagram Protocol [IETF]
VC	Virtual Channel
VCI	Virtual Channel Identifier
VDSL	Very high speed Digital Subscriber Line
VoDSL	Voice over Digital Subscriber Line
VP	Virtual Path
VPI	Virtual Path Identifier [ATM]
VTP	VDSL Termination Processing
VTP/D	VDSL modem with Protocol processing and Decoding
WAN	Wide Area Network
This list was produced by Telecom Acronyms www.acronyms.bt.com/	

3. DEFINITIONS

In this document several words are used to signify requirements which are often capitalised.

MUST This word, or the adjective “required”, means that the definition is an absolute requirement of the specification.

MUST NOT This phrase means that the definition is an absolute prohibition of the specification.

SHOULD This word, or the adjective “recommended” means that there may exist valid reasons in particular circumstances to ignore this item, but the full implications must be understood and carefully weighted before choosing a different course.

MAY This word, or the adjective “optional”, means that this item is one of an allowed set of alternatives. An implementation, which does not include this option, **MUST** be prepared to inter-operate with another implementation, which does include the option.

ACCESS NETWORK DOMAIN

The Access Network Domain encompasses the domain between the U-R and V interface of the system reference model.

CORE NETWORK DOMAIN

The Core Network Domain takes place beyond the V interface and the OLT physical interface.

SERVICE OPERATION DOMAIN

The Service Domain includes the physical equipment of multiple or single service nodes that interface the Core/AN and provide users access to various services including data connection, broadcast video, VoD, and voice.

FP

Functional Processing. A point of signal transformation or processing.

FPD

Functional Processing and Decoding. Typically terminals performing the application layer processing of video, audio and data, e.g., Set top box (STB).

VTP

VDSL Termination Processing. Refers to the unit that operates the VDSL modem termination and protocol processing functions. A device that implements the VTP functions includes Ethernet based layer-2 interface to the in-home Network.

VTPD

VTP and Decoding. Refers to a unit that operates the video decoding function as well as the VTP functions and interfaces.

VTP/D

When mentioned in this document, refers to both the VTP and the VTPD

RESIDENTIAL CENTRALISED MODEL

When mentioned in this document, refers to the use of the VTPD as the decoding unit.

RESIDENTIAL DISTRIBUTED MODEL

When mentioned in this document, refers to the use of multiple STBs that are connected to the VTP through the in-home LAN.

4. REFERENCES

- [1] FS-VDSL Part 3 Version 1.0 Section 7.9.
- [2] FS-VDSL Part 2 Version 1.0
- [3] FS-VDSL Part 3 Version 1.0 Section 11.2.1.

5. FUNCTIONAL DIAGRAM

It is essential that the functions that are specific to the FS-VDSL specific platform are identified and the interfaces to the platform that are required are defined to a sufficient level of detail. In an effort to help understand the linkage between processes and the functions that relate solely to the FS-VDSL platform the following flow diagram has been formulated. This gives the platform four functional areas, Network Provision, Network Data Management, Service Quality Management and FS-VDSL Maintain and Restore. It also identifies the interfaces to the platform.

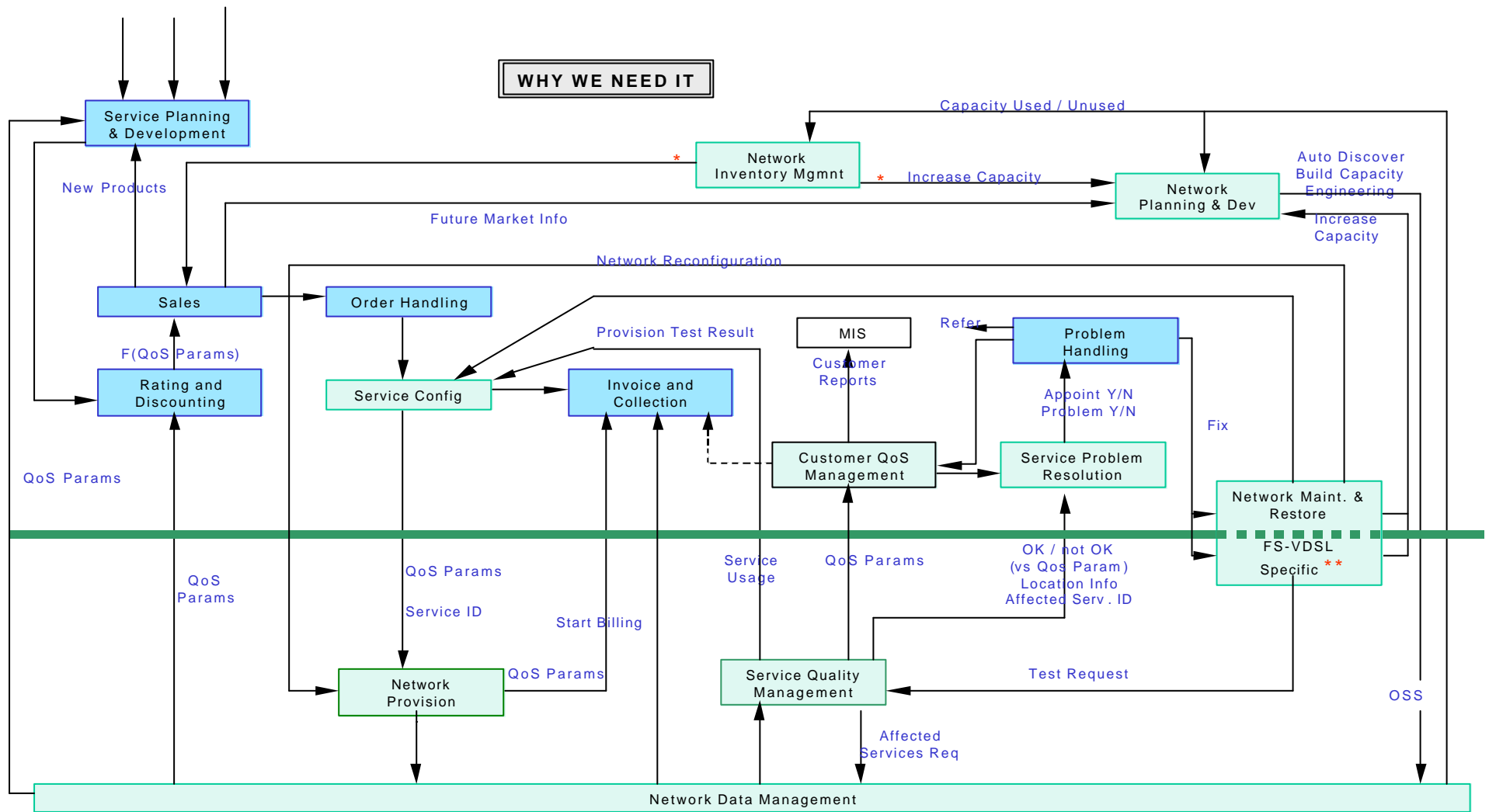

Key :- Network Domain Service Operation Domain

THE FUNCTIONALITY WE NEED

* = Auto Detect
 ** = Access Domain (VDSL Transport)
 In Building Network
 Set Top Box

Figure 1: FS VDSL Platform

6. NETWORK PROVISION

6.1. INTRODUCTION

This section includes a number of requirements aimed at making the installation of network elements and the configuration of the network elements in response to a request for a new service, quick and easy to accomplish.

The FS-VDSL group is not concerned with the precise set-up of a given service once the network has been configured sufficiently to support it. It is expected that the Service Operation Domain will do this. The one exception to this is controlling access to broadcast video channels which will be managed within the FS-VDSL platform.

The following diagram shows the Network Provision functionality broken down into three distinct stages. The requirements for each stage are dealt with in the next three sections.

The text in the right hand column suggests the domain(s) most likely to be responsible for the stage.

The text in *italics* in the centre column identifies those parameters that must be passed into, or out of, the FS-VDSL platform (see interface specifications in section 12 for more details).

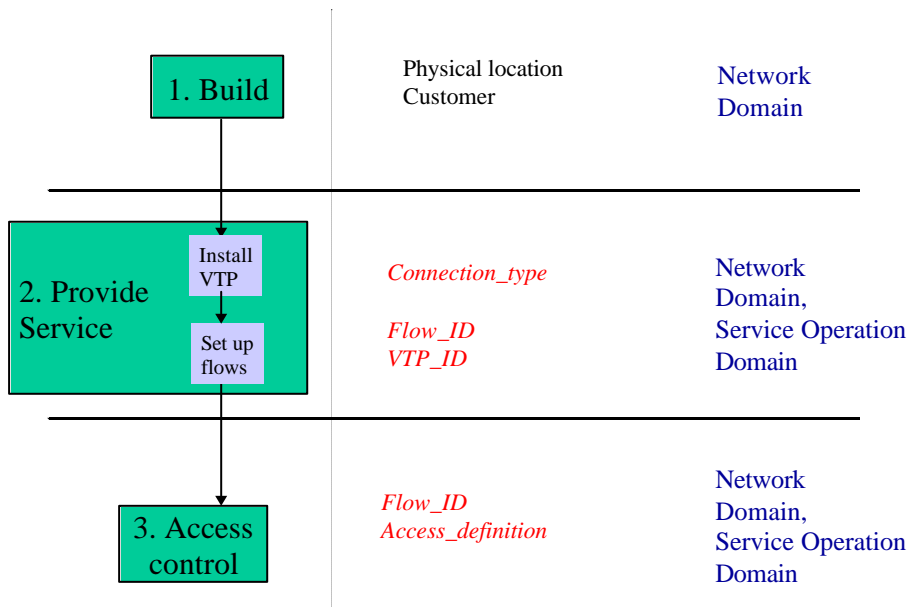

Fig 2 Network Provision Functionality

6.2. STAGE 1 - BUILD THE NETWORK

The first stage is to build the network. This includes both providing network equipment in new geographical areas, and adding capacity to an existing Core and Access Network Domains. It is up to the Network Domain to maintain records of which specific areas could potentially be served by the equipment that is installed. **These records will be kept in the Network Domain's OSS, not within the FS-VDSL platform.** Note that at this stage the VTP will not be installed.

6.2.1 AUTO DISCOVERY AND AUTO CONFIGURE

Any equipment added to the platform during a build activity must be auto-discovered and configured by the FS-VDSL platform. This is a key operations requirement.

6.3. STAGE 2 - PROVIDE SERVICE

Once network capacity is available the Service Operation Domain will sell services to individual customers. This will in turn result in the Service Operation Domain asking the Network Domain to provide network capability to a specific customer, upon which the service will be carried. The Network Domain must determine which ONU will serve the end user using information in their own inventory database in addition to determining if there are any reach constraints. This is not a function of the FS-VDSL platform.

6.3.1 INSTALLATION OF THE VTP

The end user's copper pair will be connected to a spare port on the ONU. There is no requirement to stipulate which port will be used (although this can optionally be specified). Upon connection of the VTP at the far end of the copper pair, the FS-VDSL platform must auto-detect the VTP, read its unique VTP_ID (e.g. its MAC address or serial number), and add it to the inventory information held within the platform (usually within the EMS). Note that, during this part of the service provision activity, there is no requirement for any information to cross from the NML into the FS-VDSL platform.

6.3.2 MANAGEMENT OF THE VTP/D

Note that any management of the VTP/D that is undertaken in the Core and/or Access Network Domain must be performed via the VDSL EMS. The ability for a customer to configure the VTP locally e.g. via an HTML interface is optional.

A method of raising an event from the FS-VDSL platform to indicate that a VTP has been connected, which ONU port it has been connected to, and what its VTP_ID is, must however be provided. This is required to deal with the case where the Network Domain does not provide the VTP and therefore has no prior knowledge of its VTP_ID.

The Service Operation Domain will maintain the relationship between each VTP and the customer it serves, using the unique VTP_ID. It is expected that the Service Operation Domain will use an existing customer database to store this relationship. **Note that this relationship is not held within the FS-VDSL platform.**

6.3.3 SETTING UP FLOWS

The request to provide service to a particular customer will, as far as the FS-VDSL platform is concerned, be a request to set up one or more ATM flows, which must be of one of the ATM flow types defined in the CPE specification document ^[1]

The request will be sent from the Service Operation Domain to the Network Domain. The Network Domain will determine the precise flows that need to be set up and instruct the FS-VDSL platform to set them up to a given VTP-ID. Note that at this stage the VTP-ID for a given customer must be known by the Service Operation Domain and/or the Network Domain. This will be achieved either because the VTP is provided by the Network Domain or because the VTP-ID has been discovered by the platform and reported back to the Service Operation Domain.

Before any attempt is made to set up a given flow, a check must be made to ensure that the VTP can support the flow requested.

Once a given flow has been set up successfully on the FS-VDSL platform, the platform will assign to it a unique identifier known as the flow_id. This flow_id will include the VTP_ID. This will be reported back to the NML as an event via the EMS, and must only be reported once the path between the VTP and the Service Operation Domain's gateway has been verified at the ATM layer. The FS-VDSL platform must initiate this verification activity automatically.

The event report can be used by the Network Domain or Service Operation Domain to initiate a service verification activity that ensures the VTP can access the service— for example, a 'welcome' web page or video signal. **Note that this service verification activity is not part of the FS-VDSL specification.** The platform can only verify flows at the ATM layer.

The flow_id is used within the platform to identify a specific flow to a specific VTP_ID. The Network Domain and Service Operation Domain will use the flow_id to

identify specific services to specific customers, by relating the flow_id to services and customers within their own NML systems.

The primary identifiers for performing OAM&P functions on the FS-VDSL platform are the VTP_ID and flow_id. These are used extensively by the platform during most OAM functions. The format of these identifiers are given in ^[1]

Consideration needs to be given to the situation where a customer changes a VTP without interaction with the Network Domain. There is no functionality specified for inclusion within the FS-VDSL platform to deal with this, as it is possible to deal with the situation in the service operation domain using the functionality already specified.

Consideration should be given to having pre-defined sets of flow configurations that correspond to specific types of service (e.g. three channels of broadcast video with IGMP channel control), to simplify the interaction between the Service Operation Domain, the Network Domain and the FS-VDSL EMS. This is an optional requirement that could be built into the FS-VDSL EMS.

Note that all flow set-up within the FS-VDSL platform must be performed remotely via the EMS. No site visit should be necessary to undertake any of the functions described in paragraph 6.3.3. It should also be noted that connection of the VTP can be performed by the end user, thus eliminating completely the need for any customer site visit by Network Domain or Service Operation Domain personnel.

6.4. STAGE 3 – ACCESS CONTROL

Once a service has been provided, there may be a need to change some parameters of that service at a later date. The only service-specific parameters that form part of the FS-VDSL OAM specification are those associated with access control to support broadcast video channel switching. It must therefore be possible to download an access control bitmap ^[3], that defines what multicast ATM flows the customer is able to connect to. This access control bitmap can be associated either with a given flow_id or VTP_ID. If only the VTP_ID is specified the matrix will apply to all flow_ids containing that VTP_ID. This functionality means that different levels of access can be provided for different flows to the same VTP, which enables (for example) multiple users to be supported via the same VTP

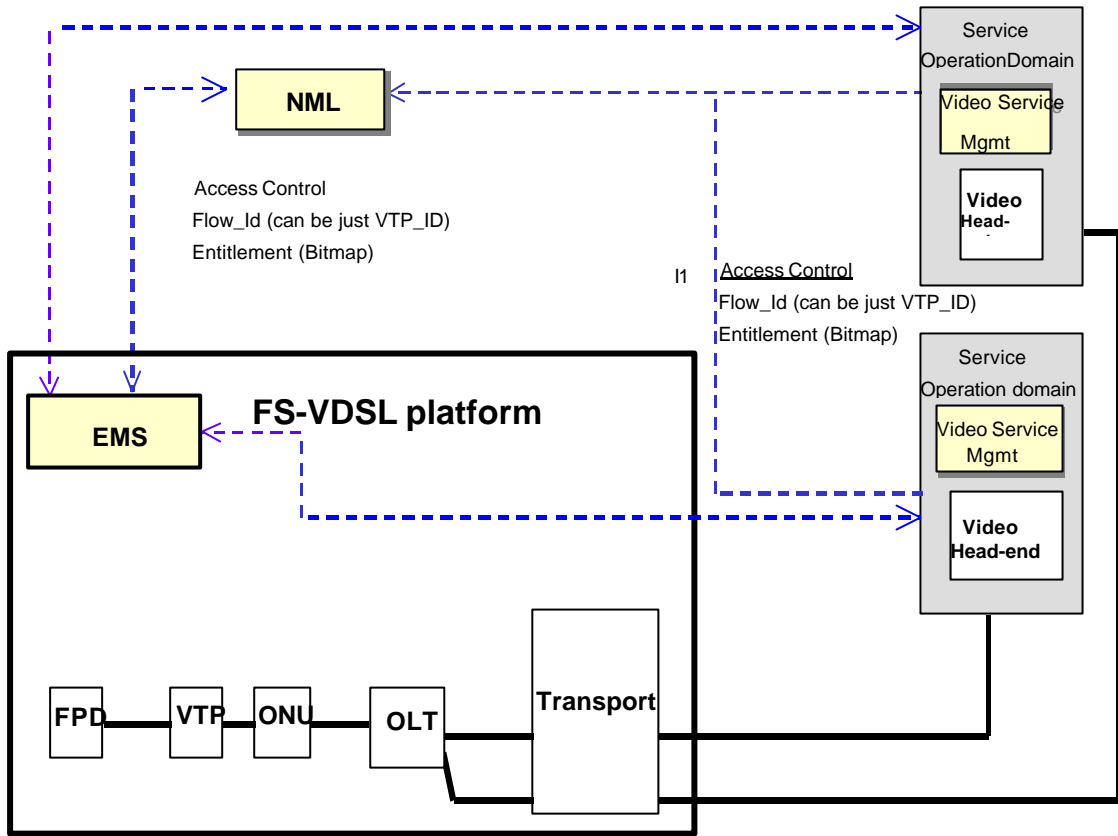

Figure 3 Access Control Channels

7. NETWORK DATA MANAGEMENT

7.1. USAGE DATA

Charging scenarios that have been considered are

- Charging by bits transferred
- Charging by elapsed time
- Charging by time of day (implies date stamping)
- Charging by access to content - Metasignalling data
- Charging by access to content for a limited time - Metasignalling data
- Charging according to QoS

It is expected that most charging information will come from outside the VDSL platform e.g. the Service Operation Domain. For this reason only limited usage information is specified as being stored within the VDSL platform

The approach taken is to allow ATM switching event logging and ATM cell count logging to be activated on a per flow_id basis if required by the Service Operation Domain.

Service usage events must be stored within the platform so that they can be extracted by Domain specific OSS. The platform will be capable of storing service usage data for a period as specified by the domain.

7.1.1 ENSURING ACCURACY OF USAGE INFORMATION

VTP MAC ID's, Serial Numbers and IP addresses must match individual customer service subscriptions and service requests. Most of these relationships are held outside the FS-VDSL platform, however it is essential that 100% accuracy is maintained within the platform between VTP_ID, flow_id and ATM level usage information (see 7.1). Service level agreements with Service Operation Domains will drive this requirement for extreme accuracy, this may be more challenging when the VTP is not provided or managed by the Network Domain. There is a need to provide an optional facility to allow only the first VTP to be recognised unless the Network Domain intervenes (see 6.3.3.)

Note: - Much of the billing may be done by the Content Service Domain and therefore may not need to be supported by the VDSL platform

7.2. TOPOLOGY (RELATIONSHIP BETWEEN EQUIPMENT AND SERVICES)

It must be possible to generate a list of physical hardware and software components, using terminology defined in the System Architecture group document ^[2], that are used to deliver a particular instance of a particular service (service instance). This would for example enable the NML to look for relevant alarms in response to a trouble report.

There should be minimum manual inventory and configuration recording.

7.3. UTILISATION / CAPACITY MANAGEMENT

It must be possible to generate a list of all components in the platform, using standard FS-VDSL terminology, showing the total capacity and the current utilisation of each component. This will enable capacity planning rules to be set in the NML. It should be possible to mark unused capacity as reserved.

There needs to be a facility to hold configuration information including that of pre-provisioning and capacity reservation during maintenance activities.

7.4. EQUIPMENT INFORMATION

It must be possible to obtain the following information for all FS-VDSL Inventory where applicable: - Software version, hardware version, serial number, MAC address, IP address, ATM address, Vendor and model number

8. SERVICE QUALITY MANAGEMENT

For a specific customer Flow_ID there is a requirement to:

- Auto report QOS exceptions based on downloaded thresholds. The requirement from the Network Domain is real time, the vendor should be able to advise the maximum delay between the exception occurring and the report being generated
- Ability to report QoS parameters on demand
- Ability to reports QoS parameters against pre-defined schedule (i.e. timescales)
- Ability to feed in QoS thresholds

Any QoS exception report must have an associated location statement and suggested course of action to clear the problem that indicates the root cause and if desired only the root cause. The diagram at ^[2] Fig 1 defines the minimum set of locations. The suggested course of action statements must be human readable text no greater than 1024 characters. Note that a valid corrective action could be to increase capacity at a given network node or link between nodes

- Location statements should define a FRU (Field Replaceable Unit) or bearer if appropriate
- Distance to fault along bearer is optional

9. FS-VDSL NETWORK MAINTENANCE AND RESTORATION

9.1. GENERAL REQUIREMENTS

- There should be no prevention of the testing of telephone apparatus, baseband telephony service or ISDN service
- There is no requirement to gain information about the FPDs.
- It is assumed that there will always be an ATM layer in VDSL between DSLAM and VTP
- The OLT and ONU must include a local access port for manual access to system information including alarms and MIBs.
- Test functions if required by a Network Domain must manage subscriber drop testing and channel testing.
- The OAM functionality of the interface between the FS-VDSL platform and legacy PSTN platform needs to be defined if VoDSL services are to be supported. This is currently not part of this specification
- The facility to extend alarms to physical contact monitoring systems within the CO is optional. Alarm unit and alarm test unit options can include:
 - Contact closure alarm inputs
 - Loop closure output alarms
 - Alarm severity and location indicators
 - Bay lamp control
 - Alarm cut-off switch with alarm cut-off LED
 - Channel test
 - Serial interface driver
 - Digital by-pass support
- Each FRU (e.g. linecard, VTP/D) must have a visible indication of status: as a minimum active /non-active/ error. These indications must be consistent with alarms as indicated on the EMS, in addition the VTP/D should indicate the VDSL link status
- It is assumed that correlation between the FS-VDSL platform alarms and alarms from other network elements will take place in Network Domain specific OSS and is therefore not part of this specification.
- Regular, on-site maintenance tasks should be minimal.
- This information must reveal pertinent VTPD internal information, network conditions, channel selection problems, pay-per-view problems, interactive-program guide problems, etc. VTPD operational problems consist of video problems, audio problems, channel selection problems, remote control problems, telephony problems, and PC / Ethernet problems. While VTPD operational

problems can be detected by a technician upon installation, they are unfortunately more commonly reported by valued customers after initial installation.

- IP based services shall be managed using SNMP messages as per RFC 1157 and maintain a MIB in the format defined in RFC 1213 MIB entries should include Diagnostics, Fault Detection and Hacker detection.
- Power shedding is also required to turn off non-essential services during a disruption of commercial AC power to a remote power supply. Turning off broadband services conserves RPS battery power to ensure up to eight hours of battery power for emergency telephony services. It is recommended that power shedding be automatically initiated by an OLT upon receipt of a loss of AC power or be manually requested by users.

9.2. ELEMENT MANAGEMENT SYSTEM

- Information about the Element Management System is required, the parameters being :Disk space , memory and CPU usage against resources allocated to the EMS, status of the links between the EMS and nodes,
- The format of the alarms i.e. how they are reported to the NML, is not part of this specification. However a recognised industry standard should be used if possible.
- It must be possible to change the priority of alarms within the EMS, with a minimum of three different priorities (e.g. Major Minor Intermediate)
- It must be possible to configure the length of time alarm information will be kept
- It must be possible to define thresholds on reportable alarms

9.3. MODEM INFORMATION REQUIRED

- Upstream rate and SNR
- Downstream rate and SNR

9.4. VTP INFORMATION REQUIRED

- The VTP may be able to check connectivity between VTP-D and other devices in the customer premises (FPDs) including round trip delay. If this feature is provided then the information must also be available via the EMS

9.5. LINE

- Consideration should be given to testing the integrity of the copper pair if there is not the capability to see far end equipment.
- Copper line test on PSTN should not affect VDSL transmission capabilities

9.6. VDSL INTERFACE

- Alarm to notify the inability to achieve a certain rate with a given SNR
- Status indication for “retrain”
- Time since last instance of “retrain”

9.7. EVENT HANDLING

- The first instance of an event should be recorded. All identical events within n seconds should be suppressed but counted and made available for inspection. n must be a configurable parameter.
- The event shall be considered to be cleared after the last recorded event has not reoccurred for m seconds. m must be a configurable parameter.
- There is a requirement to be able to acknowledge alarms/events to prevent further notifications, these acknowledged alarms should be recorded.

9.8. ONU CPU

Environmental sensors and local alarms have been unanimously identified as requirements for the ONU. The list of alarms that should be generated inside the ONU

- Failure of power unit local or remote
- External door open
- Battery high temperature
- High / Low temperature

This implies that in the ONU there must be an alarms management system capable of collecting alarms from sensors/contacts and reporting them using an OAM channel back to the EMS.

- There is a requirement to know the load and status (OK / not OK) of each CPU.
- If in redundant mode an alarm should be generated, which notifies that a switch has taken place.

Repair and maintenance of the ONU should be supported with minimum service interruption. Thus the ONU should support, as far as possible, hardware replacement (hot swap) and in-service software upgrades, without losing existing configurations

9.9. OPTICAL INTERFACE

- Indication of Laser Diode Degradation or failure
- Indication of OF transmission capabilities (SNR)

9.10. ONU

- Internal alarms to include High/ Low temperature
- External alarms may include open door, fans, moisture, battery status
- Power loss

9.11. ATM

- The platform must support full F4 and F5 OAM flow functionality as defined in I.610
- It must be possible to set up at least the following segments, VTP – ONU. ONU – OLT, VTP - OLT
- Access line loop back will occur at the ONU or VTP depending on the direction
- Inter domain loop back to occur at the Service Operation Domain gateway

10. OSS

10.1. SOFTWARE UPGRADES

10.1.1 VTP/D SOFTWARE

This section applies to, as a minimum, the software required to establish ATM flows as defined in ^[2]. This software is hereafter referred to as Operating Software.

The VTP/D should have a back up bootstrap that can retrieve an operational load as described in SA/CPE documents. BOOTP must be available and independent of the downloaded software image. An additional VTP/D option is to have two separate sets of operating software, active and passive.

The management system will download a new version, using the following steps:

- Identify the model and manufacturer of the VTP/D.
- Make sure that the needed software for that VTP/D is available.
- Deleting the passive software.
- Downloading a new version to the area cleared by the delete action.
- Switching between active and passive

Immediately after every start-up – synchronisation process of each port, the management system will check that the active software of the VTP/D is the one planned for that port. If the software is not as planned, then the following steps will be taken:

- Check if the passive software is the one planned for that VTP/D.
- If yes, then a switchover process will be initiated, causing the VTP/D to lose its synchronisation, activate the passive software, and going back to sync and service, using the planned software.
- If the passive software is not the one planned for that VTP/D, then the process described above for a new version will be done.

Usually, but not necessarily, in a new VTP/D shipped to an end customer, those 2 sets are identical.

In order to avoid denial of service because of a failure to complete the software upgrade procedure, the VTP/D, will perform some tests before switching over to the version stored on its passive area. All conditions must be fulfilled:

- The length of the file is correct.
- CRC is ok.
- File name matches the planned one.
- File name matches the type of VTP/D connected to that port.

If one or more of the conditions listed in the previous paragraph fail, then:

- The switchover process will be cancelled.
- The passive area will be deleted.

It is recommended that each version of software will have a unique length.

Deleting the passive area, and downloading process, will take place even during active sessions performed by the customer, using the UBR OAM&P VC connection.

It is preferred that the management system will not switchover during an active session: There should be the facility for the management system to force the switchover at any time or switchover at the next start up cycle.

It should be possible to initiate an upgrade on Multiple VTP/Ds e.g. grouped by the following:

- One line card
- Specific ONU
- All ONU of one OLT
- Minimum requirement is the ability to initiate an upgrade of all VTP/Ds on an OLT with a single command

The system must be capable of distinguishing between types of VTP/Ds in order to download the matched software to the right VTP/D

An optional requirement is the ability to activate or de-activate a specific flow e.g.: video only or data only on a multi-service VTP/D without impacting other flows.

10.1.2 VDSL PLATFORM SOFTWARE

The FS-VDSL platform must include a “hitless” software feature where once a software component has been upgraded, it will upgrade subsidiary software components if necessary (ensuring service is unaffected where possible) e.g. an OLT software upgrade might trigger a linecard upgrade when all circuits are idle

10.2. ELEMENT MANAGEMENT SYSTEM

There should be the facility to access all FS-VDSL OAM functionality through a human interface on the EMS as well as the EMS providing an interface from the Network Domain specific OSS to give access to the same set of functionality.

Vendor EMS documentation must describe all alarm messages with the following corresponding information.

- Alarm message text
- Default Priority
- Alarm type (optional)

- Description
- Recommended Resolution

The EMS hardware, operating systems and network technology must use Industry Standard hardware and software.

Geographically dispersed deployment with centralised EMS management capabilities must be supported using industry standard LAN / WAN protocols e.g.TCP/IP over Ethernet. In band communications are preferred.

EMS user interface (both local access and remote) must be via HTTP web based industry Standard GUI. No proprietary software will be required on the client machine.

All attempts to access EMS must be protected via standard Username and Password applications either remotely via an automated security mechanism (OSS generated) or locally when logging on via the human interface. A facility to allow time limits to be set for username/password combinations must be provided.

10.2.1 EMS ADMINISTRATION

The EMS must support at least the following **Administration Tasks**:

- Starting EMS with default configuration files
- Starting EMS with Network Domain defined configuration file
- Starting EMS without a configuration file
- Selecting a configuration file from a list
- Managing user accounts including the ability to limit the access to functionality on a per user / group basis. This is to facilitate for example SP access to specific functions within the EMS.
- Setting alarm message destination
- Changing alarm message destination
- Redirecting VDSL network element alarms
- Changing alarm priorities
- Backing up files / directories / databases
- Restoring back up files
- Manual / Automatic file and database integrity checking
- Managing active and stand by modes of operation

- DRP (Disaster Recovery Plan)
- Automatic or manual Upgrading / Downgrading VDSL EMS software. Manual mode upgrades allow for upgrading of system components one at a time while automatic mode upgrades the complete system.
- Purge superfluous information and files
- Manage and maintain log files e.g. alarms / history / provision
- Restoring the EMS following loss of network
- Restoring EMS following server crash / loss of power
- Protect critical system file structure
- Starting / stopping an alarm client
- Sorting and filtering system messages
- Viewing performance of EMS
- Setting performance of EMS thresholds

10.2.2 EMS EQUIPMENT PROVISIONING

FS-VDSL EMS equipment provisioning includes:

- Creating and configuring a node icon for each network element in the VDSL platform, saving this information in a configuration file. Auto discovery of network elements that are connected to the VDSL platform is a requirement. (see section 6.2.1.)
- Setting the timing source (system clock).
- Inventory management of network elements.
- Managing cross connects in each OLT if applicable.

10.2.3 EMS SERVICE PROVISIONING

FS-VDSL OSS (Operations Support Systems) service provisioning activities include:

- Control authorisation of PPV programming (see section 6.4.)
- Restore VTP to known default configuration, e.g. to clear parental lock

10.3. OSS: ADDITIONAL OAM&P REQUIREMENTS

10.3.1 OSS OPERATING SYSTEMS SUPPORTED

- UNIX Solaris X.X
- Windows 2000
- Windows NT

10.3.2 OSS HARDWARE PLATFORMS SUPPORTED

- SUN UNIX – i.e.: E250/E450
- IBM 5600 series
- Network Domain / Service Operation Domain choice

10.3.3 OSS USER INTERACTION SUPPORTED

- Web based
- Client Server
- X-Windows
- GUI

10.3.4 OSS WORKSTATION REQUIREMENTS

To match Network Domain or Service Operation Domain specific OSS configuration.

10.3.5 SERVICE MANAGEMENT

Subscriber management system must support the creation, deletion, and modification of a service. Communication options include:

- Communication via RFC1483/AAL5/ATM
- SMC-CC application download/AAL5/ATM
- Metasignaling/AAL5/ATM
- SNMP/UDP/IP

Subscriber management system may be capable of supporting auto-population of information received from an external OSS. Options include:

- MMI
- HTTP requests
- XML

Subscriber management system must be capable of deleting a service and generating deletion of an end customer record.

Subscriber management system must retain record of provisioned services.

Subscriber management system must support profiling and long-term analysis of customer viewing patterns.

10.3.6 FAULT MANAGEMENT

- System Architecture must be capable of transmitting fault information to the EMS. Events are captured and transmitted to EMS using SNMP v1 and v2 traps.
- EMS must support multiple user-defined alarms.
- EMS must be capable of managing multiple VDSL system configurations.
- EMS must be capable of performing root cause analysis on fault information.
- EMS must support multiple users and simultaneous user sessions.
- EMS must support partitioned view of managed network elements.
- EMS must support auto-discovery of network elements.
- FS-VDSL System Architecture EMS must support transmission of fault information to an NMS. Fault information can be forwarded to NMS via SNMP or industry standard interfaces.

10.3.7 CONFIGURATION MANAGEMENT

- Creating and configuring a node icon for each network element in the VDSL platform, saving this information in a configuration file

- Auto discovery of network elements that are connected to the VDSL platform is a requirement
- Setting the timing source (system clock)
- Inventory management of network elements
- Managing cross connects
- Auto discovery should automatically populate the inventory management system or allow real time interrogation to obtain inventory data.

10.3.8 CONTENT MANAGEMENT

- System must support adding / modifying / deleting of services.
- System must support channel insertion into customer profile or service packages.

10.3.9 BILLING

- System billing functions and capabilities must address billing record format.
- System billing functions and capabilities must support secondary billing number (unified billing).
- System billing functions and capabilities must support video service subscription.
- System billing functions and capabilities must support promotional programming discounts.
- System billing functions and capabilities must support real time service transactions – i.e.: PPV / VOD.
- System billing functions and capabilities must support service credits.

11. INTERFACES TO THE FS-VDSL PLATFORM

(The term interface refers to the OAM information exchange that occurs between the NML and the EMS)

The following interfaces are defined for an FS-VDSL compliant Element Manager:

The interfaces are specified here in 'human readable' terms. It is likely that a MIB will be defined to support them. However it is also permissible for a compliant FS-VDSL system to use another interfacing technology, e.g. CMIS/CMIP.

11.1. GENERAL INTERFACE REQUIREMENTS

- Any request into the platform must give a success / fail indication

11.2. TO SUPPORT SERVICE PLANNING AND DEVELOPMENT

- May supply usage information including fixed cost services e.g. viewing statistics, user demand at specific times, utilisation of IP path capacity.
- May supply information on the availability of platform capacity at various levels of granularity e.g. specific ONUs

11.3. TO SUPPORT RATING AND DISCOUNTING

- Must supply a list of usage statistics that are supported by the platform
- Must have access control mechanisms that are supported
- May report on non invoiced usage.

11.4. TO SUPPORT NETWORK PROVISIONING

- To initiate an instance of service (creates flow_id on platform)

11.4.1 TO PLATFORM

- Must :- Reserve Service type, identifier of ONU, ONU port , null means use next available, the service type as defined by ^[2]
- Must : - activate service, flow_id, QoS parameters (null in this field means use default QoS parameters for service type)
- Must : Expected VTP identifier i.e. serial number, MAC ID. Can be null in which case any VTP is accepted.
- May :- Additional ATM service types, the parameters are VPI, VCI, traffic type and PCI
- May :- Pre- defined bundles of service types

- Must : - Set default QoS parameter values , Service type, default QoS parameter values
- Must : - Show service types.

11.4.2 FROM PLATFORM

- Must :- flow_id for each successful service reservation request
- Must : - list of service types, default QoS parameter values for each type of service
- Must : - Event to indicate that VTP has been connected, ONU port, VTP ID
- Must : - Event to indicate flow established successfully, Flow ID

11.5. TO SUPPORT NETWORK PROVISIONING

to cease an instance of service

- Must :- Stop flow_id
- May :- Stop , list of flow_ids

11.6. TO SUPPORT NETWORK PROVISIONING

to restore service following a problem report

- Must : - Reserve flow_id, platform will reject flow_id that is not current
- Must : - Stop flow_id
- Must : - Reserve and activate as in initiation of an instance of service except the flow_id is specified to the platform. The platform must reject a flow_id that is not reserved.

11.7. OUTPUT FROM NETWORK PROVISIONING

to initiate billing

- Must supply flow_id with date / time stamp from the platform showing when verification of service is completed
- Must supply flow_id with date / time stamp from the platform showing when cease of service is completed

11.8. TO SUPPORT INVOICING AND COLLECTION

To bill using per-use information

11.8.1 TO THE PLATFORM

- Must : - Request for usage information by flow_id , start time / stop time
- Must : - Activate switching event logging, flow_id
- Must : - De-activate switching event logging, flow_id
- Must : - Activate ATM cell count logging , flow_id
- Must : - De-activate ATM cell count logging , flow_id
- Must : - Set usage information storage time , number of seconds to keep information

11.8.2 FROM THE PLATFORM

- Must : - flow_id, cell count, switching events

11.9. TO SUPPORT NETWORK INVENTORY MANAGEMENT AND NETWORK PLANNING AND DEVELOPMENT

Description of capacity in-use and available (real time snapshot)

11.9.1 TO THE PLATFORM

- Must : - Request capacity used, by Network Element ID (format to be that of FS VDSL Specification Part 2 reference model), include subsidiary Network Elements - level of granularity (nought = none)
- Must : - Request capacity available, identifier of ONU port and OLT port, the service type as defined in FS VDSL Specification Part 2
- May : - Reserve capacity, Network element ID ,amount
- May : - Release reserved capacity, Network element ID, amount
- Must : - Request element type, element ID

11.9.2 FROM THE PLATFORM

- Must : - Network Element ID, total capacity, capacity used,
- May : - Capacity reserved
- Must : - ONU port , OLT port , total capacity, capacity used
- Must: - Element ID, Software version, hardware version, serial number, MAC address, IP address, ATM address of element, Vendor ID, model number. Parameters in *Italics* can be null if not applicable.

11.10. QOS PARAMETERS TO CUSTOMER QOS MANAGEMENT

For any Flow_id

11.10.1 TO THE PLATFORM

- Must : - Request QoS exceptions, start / stop times, flow_id

11.10.2 FROM THE PLATFORM

- Must : - flow_id, QoS specified , QoS exceptions

11.11. TO SUPPORT FS-VDSL NETWORK MAINTENANCE AND RESTORATION

Monitoring of platform condition

11.11.1 TO THE PLATFORM

- Must : - get element performance information, Network Element ID, optional Flow_id, optional parameters required, include subsidiary Network Elements - level of granularity (nought = none)
- Must : - get link performance information, Network Element ID for start of link, , Network Element ID for end of link , optional parameters required,
- Must : - Set default Network performance parameter values , Network element type, default Network performance parameter values
- Must : - Set default Link performance parameter values , Start Network element type, End Network element type, default Link performance parameter values
- Must : - Alarm storage time, time in seconds

11.11.2 FROM THE PLATFORM

- Must : - Network element ID, performance parameters, optional Flow_id
- Must : - Network Element ID for start of link, , Network Element ID for end of link , Performance Parameters,
- Must: - Network Performance exception, list of affected service Ids, Network Performance expected, actual Network Performance, location of problem in terms of Network Element ID, date / time stamp, indication of corrective action required.
- May : - Distance to fault along bearer

11.12. TO SUPPORT SERVICE PROBLEM RESOLUTION AND FS-VDSL NETWORK MAINTENANCE AND RESTORATION

Test request and result (self generated, i.e. Alarm or on request) OK / not OK vs. QoS Parameters, with location and flow_id s affected

11.12.1 TO THE PLATFORM

- Must : - test, flow_id
- May : - Initiate routine QoS reporting, list of service Ids, periodicity of reporting (seconds)

11.12.2 FROM THE PLATFORM

- Must : - test result, flow_id , QoS expected , actual QoS , Ok Yes/No, location of problem in terms of Network Element ID (null if test is OK) date / time stamp, indication of corrective action required (null if test is OK), May : Distance to fault along bearer
- Must : - QoS exception, list of affected Flow_ids , QoS expected , actual QoS , location of problem in terms of Network Element ID date / time stamp, indication of corrective action required May : Distance to fault along bearer
- May : - QoS report , Flow_id , QoS expected , actual QoS , Ok Yes/No, location of problem in terms of Network Element ID (null if test is OK), date / time stamp, indication of corrective action required (null if test is OK) May : - Distance to fault along bearer

11.13. TO SUPPORT ACCESS CONTROL FUNCTIONS

11.13.1 TO THE PLATFORM

- Must : - Set access bitmap , flow_id, VTP ID, entitlement bitmap, if no flow_id specified bitmap applies to all VTP associated with that flow ID
- Must : - Read access bitmap , flow_id. VTP ID.

11.13.2 FROM THE PLATFORM

- Must : - flow_id, entitlement bitmap

12. VTP/D - ADDITIONAL OAM&P REQUIREMENTS

12.1. VTP/D MANAGEMENT FUNCTIONS

VTP/D should be capable of being managed remotely. Management protocols include:

- in-band channel management via CLI, Web or SNMP
- ATM reserved PVCs
- HTTP / Web interface
- telnet/CLI interface
- ILMI for ATM layer configuration
- DSL embedded operation channel
- XML

VTP/D inventory information to the EMS should include the following attributes, this information is already included in the VTP management model defined in the CPE spec:

- Vendor name
- Hardware version
- Software version
- Serial Number
- Device type
- Date and time of installation
- MAC ID

Management connectivity is required from VTP/D to EMS, management channel is defined in ^[1]

VTP/D remote reset functionality is required. Example: Performing a warm or cold restart of the VTP/D. Groups of VTP/Ds can be reset via EMS scripting, manual and automated capabilities.

VTP/D diagnostics must be made available to an EMS via:

- Inventory information
- Physical interfaces status with associated counters

- ATM VC configuration including encapsulation supported and associated counters
- Bridging and routing tables and associated counters
- Filter state
- SNMP traps
- IP configuration
- DHCP server parameters
- PPP configuration and status
- Broadcast TV status
- Previous boot information – date / time
- MIB
- IP address
- Subnet
- Gateway
- Physical layer
- ATM layer
- Encapsulation
- PPP protocol
- IPsec

VTP/D must be capable of receiving downloaded information – i.e.: software / firmware update / other files). The download protocol is defined in ^[1]

Information must be uploaded from a VTP/D to an EMS. Protocol options to perform this functionality include:

- SNMP
- HTTP Web interface

12.2. VTP/D MANAGEMENT INTERFACES

External Craft Support interface capability is required e.g.:

- RS232
- RJ45
- USB

External LAN interface capability is required e.g.:

- 10/100 Ethernet RJ45 jacks

Management of Virtual Circuits via:

- ILMI
- Remote management

12.3. VTP/D MANAGEMENT PROTOCOL SUPPORT

- SNMPv2
- HTTP

12.4. VTP/D DIAGNOSTICS

Diagnostic information allows for prompt trouble resolution and positive internal and external customer satisfaction. CPE profile, VDSL, ATM AAL5, IP, etc. statistics must be available and displayed accordingly.

12.5. VTP/D FAULT MANAGEMENT

- VTP/D must be capable of transmitting fault information to EMS
- EMS must support user-defined alarms
- EMS must be capable of performing root cause analysis
- EMS must be capable of managing multiple VTP/D devices.
- EMS must support multiple simultaneous users.
- EMS must support partitioned views of managed VTP/D on a per user or per group basis. Example: Up to 8 levels of partitioning that supports users and groups
- EMS must support auto-discovery of VTP/D or new cards within VTP/D
- EMS must support transmission of fault information to an NMS. Example: TL1, SNMP

12.6. VTP/D CONFIGURATION MANAGEMENT

- VTP/D must be capable of retrieving configuration information from an EMS
- EMS must be capable of updating or changing software or firmware on VTP/D
- EMS must be capable of receiving and processing VTP/D configuration information from a higher level system and in turn download to respective VTP/D devices. Example: CORBA interfaces, SNMP interfaces and XML over HTTP or HTTPS
- EMS restoration time to recover from an unscheduled shut down must be minimal. Example: Maximum of 10 minutes – non service affecting
- EMS time to migrate from an existing management platform to a new hardware platform must be minimal. Example: Maximum of 30 minutes – non service affecting
- Upon recovery from a network outage, an OSS must be capable of recovering and in turn auto discovering multiple network elements within a minimum of 10 minutes.

12.7. VTP/D PERFORMANCE MANAGEMENT

- VTP/D must be capable of maintaining VTP/D specific performance for retrieval by an EMS. Example: SNMP traps
- EMS must be capable of retrieving performance information from a VTP/D. Example: SNMP traps
- EMS must be capable of reporting VTP/D performance information to a higher level system at scheduled intervals or on an on demand basis. Example: ftp of information on real time or on a scheduled basis.

12.8. VTP/D SECURITY MANAGEMENT

- OSS must support multiple user levels. Example: At GUI application level.
- OSS must be capable of logging history if user activity. Example: Logged at GUI level for a TL-1 agent.
- OSS must be capable of centralised user management via network based authentication.

13. TRAINING

Troubleshooting procedures for VDSL head end network elements must guide Network Domain personnel through steps which will result in resolution at the circuit card level. Processes must include information about alarms and visual indications to isolate and clear troubles. Procedures must minimise service interruption to subscribers.

Detailed hard copy and soft copy documentation must be made available prior to initial installation and service activation. Updated information is also to be provided to the Network Domain prior to any / all related software / hardware upgrades. Release summary must be included.

Flow charts must be included in Vendor specific documentation that will assist in proactive operations maintenance activities. Tools, test sets and materials required for troubleshooting and resolving of troubles must be identified by the Vendor and supported by respective documentation. Flowcharts must be included in Vendor specific documentation which show the steps to take in identifying and clearing of alarms which relate to respective network elements and associated equipment.

It is advisable that the Network Domain have the ability to perform a standard Loop Integrity Foundation Test (LIFT) using a Pair Check meter and in turn record results. This test will indicate the physical characteristics of the telephone line with regards to resistance, capacitance, and metallic noise and frequency response. This test will reveal any major POTS troubles present on the customer's line and also statistics that can be used as reference data for future considerations. Vendors are to provide or recommend VDSL Test Sets and documentation which supports above mentioned operations activity.

Detailed OSS (Operations Support Systems) Administration hard copy and soft copy documentation must be made available prior to initial installation and service activation. Updated information must also be provided to the Network Domain prior to any / all related software / hardware upgrades. Release summary must be included.

13.1. VTP/D INSTALLATION TASKS

It is imperative that the installation tasks listed below be clearly defined in vendor specific documentation. Operations personnel must be thoroughly trained on each task and be able to execute each task efficiently and professionally on customer premise. Emphasis remains on keeping operations costs and installation / repair intervals to a minimum.

- Unpacking and verifying VTP/D components
- Installing and configuring a VTP/D
- Installing a VDSL/POTS filter
- Wiring the customer premise
- Checking the VDSL is satisfactory once installed
- Powering on and VTP/D booting sequence
- Connecting FPDs to the VTP/D
- Programming and verifying VTP/D and respective remote control units

Vendor EMS documentation must describe all alarm messages with the following corresponding information.

- Alarm message text
- Default Priority
- Alarm type (optional)
- Description
- Recommended Resolution

Pro-active maintenance, troubleshooting procedures and diagnostic screens are key to the success of VDSL service assurance. Regular, on-site maintenance tasks should be minimal. Downloading and updating of CPE software must be performed in an automated fashion via Vendor specific OSS (Operations Support Systems). Surveillance, monitoring and event reporting is also performed through respective OSS (Operations Support Systems). Alarm messages from CPE are sent through the network by means of ONUs and recorded accordingly in the OSS (Operations Support Systems).

Operational troubles must trigger LED indicators on VTP/D, generate diagnostic messages on TV screens and error messages on VDSL OSS (Operations Support Systems). This information must reveal pertinent VTP/D internal information, network conditions, channel selection problems, pay-per-view problems, interactive-program guide problems, etc.

When troubleshooting VTP/D troubles, alarms must be visible via Vendor specific OSS (Operations Support Systems). Network Operation Domain and Service Operation Domain personnel must be able to identify which VTP/D device is in alarm state by utilising OSS alarm management capabilities. VTP/D operational problems consist of video problems, audio problems, channel selection problems, remote control problems, telephony problems, and PC / Ethernet problems. While VTP/D operational

problems can be detected by a technician upon installation, valued customers unfortunately more commonly report them after initial installation.

Detailed VTP/D hard copy and soft copy documentation must be made available prior to initial installation and service activation. Vendors are required to document problem symptom, possible cause, and action required resolving product and servicing specific issues. Updated information must also be provided to the Network Domain prior to any / all related software / hardware upgrades. Release summary must be included.

13.2. OSS ADMINISTRATION TASKS

- Starting OSS with default configuration files
- Starting OSS with customer configuration file
- Starting OSS without a configuration file
- Selecting a configuration file from a list
- Managing user accounts including the ability to limit the access to functionality on a per user / group basis. This is to facilitate for example **SP** access to specific functions within the EMS.
- Setting alarm message destination
- Changing alarm message destination
- Redirecting VDSL network element alarms
- Changing alarm priorities
- Backing up files / directories / databases
- Restoring back up files
- Manual / Automatic file and database integrity checking
- Managing active and stand by modes of operation
- DRP (Disaster Recovery Plan)
- Automatic or manual Upgrading / Downgrading VDSL EMS software (see below)
- Purge superfluous information and files
- Manage and maintain log files e.g. alarms / history / provision
- Restoring the EMS following loss of network
- Restoring EMS following server crash / loss of power
- Protect critical system file structure
- Starting / stopping an alarm client
- Sorting and filtering system messages
- Viewing performance of EMS
- Setting performance of EMS thresholds